



Rendering

New High Efficiency SS-Hybrid Extrusion Press

By Takeharu Yamamoto, UBE Machinery Corporation, Extrusion Machine Design Group,
and David S. Bernardi, UBE Machinery Inc.

Editor's Note: Servo motors combined with the latest in computer technology have advanced in many heavy machine applications with great efficiency to control linear position, speed, and acceleration precisely, and they offer several functional and ecological advantages when compared with standard hydraulic systems. Hydraulic systems, though messy and slower, are essentially linear in terms of force application and are the standard in providing the large tonnages used in extrusion. Servo motors generate rotational motion and force vectors at much higher speeds, however, to be useful in extrusion applications, they require translation to linear motion, requiring additional gear drives or other means. In spite of this, servo motors have proven their worth in terms of time and energy savings, as well as reduced maintenance and space requirements. Thus, combining innovative servo motor and hydraulic systems in hybrid aluminum extrusion systems, takes advantage of both types of systems, leading to energy and efficiency savings in extrusion production. To be sure, UBE Machinery already uses servo motors in combined electric-hydraulic and even all-electric systems for their large plastic injection molding machines and aluminum die casting machines; now, UBE has incorporated servo motors in its SS-Hybrid aluminum extrusion press series described hereafter.

Introduction

With the introduction of the new SS-Hybrid press UBE has introduced the next step in its technology leadership and dedication to the environment. The press incorporates servo motor drives and an updated hydraulic system, along with other improvements to provide energy savings, increased operation speed, and improved efficiency, all enabling the new machine to reduce its carbon footprint.

Background: UBE Industries began in 1897, when it entered the coal mining business in Ube City, Japan. The company was founded by Sukesaku Watanabe, who had a vision of "creating industries with infinite possibilities from the finite resources of coal, to bring long-term prosperity to communities." The company evolved from man-

ufacturing and servicing machinery used in coal mining to include the production of equipment for the cement, chemical, and foundry industries. In 1964, UBE began to manufacture extrusion presses for the aluminum industry, and the company has grown into a global leader in aluminum extrusion press technology. The company's North American headquarters is located in Ann Arbor, MI, and in early 2015, it opened UBE Machinery Mexico, S.A. de C.V. in Irapuato, Mexico. Today, UBE Group is a worldwide family of 226 companies employing over 22,000 people driving technology development into tomorrow and beyond.

Extrusion Press Development

In 2013, UBE's research and development group established a new design team, headed by Takaharu Yamamoto, the long-time head of UBE's extrusion press design group. Yamamoto brought his 42 years of experience in engineering, design, manufacture, and processing to lead the design team through the entire process of creating the SS-Hybrid press. Drawing on UBE's long history of design excellence, he led the team with a focus on both economy and environmental performance.

Working out of UBE's R&D center in Japan, the team's goal was to share information and set themes collaboratively with the aim of developing a next generation aluminum extrusion press. The team, which consisted of UBE personnel from engineering, field service, and the research and development group, conferred with its extrusion customers, both from UBE and elsewhere, to establish a number of goals for the new design. These goals included the reduction of electric power consumption by 35-50% compared with conventional hydraulic extrusion press design, a shortened dead cycle time, a shortened die change time, decreased oil volume, easier maintenance of the main cylinder and the hydraulic units, decreased risk of oil leakage and fire around the container and end-platen, shallower machine pit depth and lower machine

height, a simplified structure and ease of maintenance of the hybrid system, noise reduction covers, a smaller die slide footprint, and reduced noise through the use of servo-motors and inverter controls on the pump motors.

The development team utilized FEM analysis from the start to the finish of designing the new press. The company's in-house foundry enabled the team to design and manufacture the complete extrusion press, from casting design through the casting process to final machining, assembly, and testing of the parts. Through this two year design and development process, the team was able to meet all of its goals in the creation of the SS-Hybrid press.

The SS-Hybrid

UBE was careful to maintain the design integrity of the SS-Hybrid (Figure 1), which is the latest iteration of their popular NPC-SSG3 model in the SS series. As noted previously, the new press was designed to make a number of improvements in terms of energy savings and efficiency. Some of those improvements are shown in Table I. The SS-Hybrid short stroke press is available in 15 MN (1,650 ton), 18 MN (2,000 ton), 25 MN (2,750 ton), 30 MN (3,300 ton), and 36 MN (4,000 ton) sizes.

Basic Structure: Following extensive testing, UBE decided to continue to use round tie bars with pre-stressed tubes in conjunction with a rigid base design for the SS-Hybrid. The press machine base is made of steel as a welded one-body package to assure the alignment, integrity, and longevity of the machine. In addition to improving robustness, the base secures the slide surface accuracy for the main cross-head and the container. Using FEM analysis, UBE found that the use of round tie bars were superior regarding deflection and alignment compared

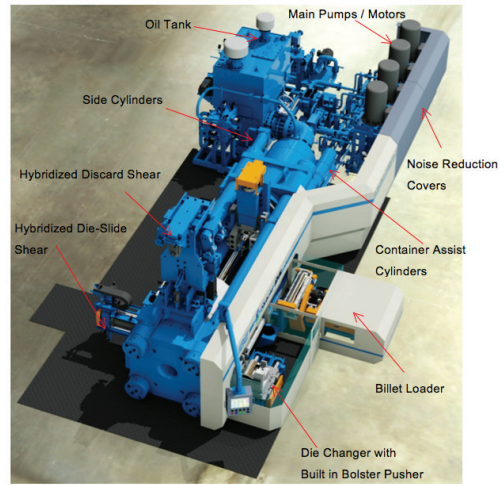

Figure 1. Overview of the SS-Hybrid press.

	NPC-SSG3 (25 MN)	SS-Hybrid (25 MN)
Dead Cycle Time (excluding upset and burp cycle – guaranteed value)	9.9 sec	8.6 sec
Dead Cycle Time (including upset and burp cycle – just calculation value)	13.4 sec ±5%	12.0 sec ±5%
Energy Consumption (during extrusion)	105 kWh	77 kWh
Hydraulic Oil Volume	6,000 L	4,500 L

Table I. Comparison of the SS-Hybrid press to the NPC-SSG3.

We Deliver World Class Performance



ENERGY SAVINGS

Save of Energy consumption Approx. 35%~50%

Hydraulic oil volume : reduced by 25%~45%

PRODUCTION IMPROVEMENT

Dead Cycle Time : Reduced by 10%~50%

QUALITY ENHANCEMENT

Enhancement of press alignment



UBE MACHINERY CORPORATION, LTD.

UBE Machinery Inc. • 5700 South State Street • Ann Arbor, MI 48108 • 734-741-7000

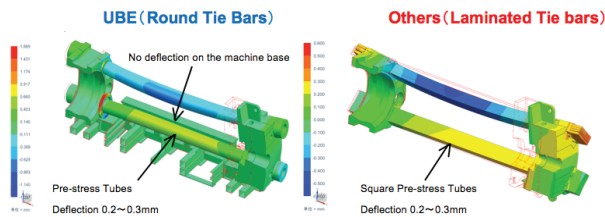

Figure 2. UBE round tie bars show less end-platen deflection than laminated tie bars.

to the use of laminated tie bars (Figure 2). On a 3,300 ton press, the deflection was found to be 0.2~0.3 mm using the laminated pre-stressed square tube or round tube tie bars. However, no deflection was shown for the UBE round tie bars.

Container: The structure of the main cross-head and container incorporates linear guides, which improves the alignment of the stem, container, ram, and container movement for faster speeds and energy savings. The container is driven by a hybrid device, combining servo motors and the container assist cylinders located in the main cylinder housing. The servo motors are fixed on the machine base instead of the container holder, so that they will not be affected by the heat and the vibration of the container.

Only three hydraulic cylinders are located around the container and end-platen, as well as two for the discard shear and two for the die slide, which are designed to decrease oil leakage and the risk of fire in those areas. The servo drives used throughout enable the system to slow the speed of the hydraulic oil and reduce pressure levels, from 310 bar (4,430 PSI) down to 210 bar (3,000 PSI). This provides a number of benefits. It reduces the risk of oil leakage and fire due to the flow rate restraint and low pressure in the hydraulic piping line. The hybridized discard shear is less likely to splash oil over the container because the cylinders for the discard shear are located on either side of the press rather than the center (Figure 3). The risk of fire can be further eliminated with an option using water glycolic hydraulic oil for the movement of the shear and the die-slide.

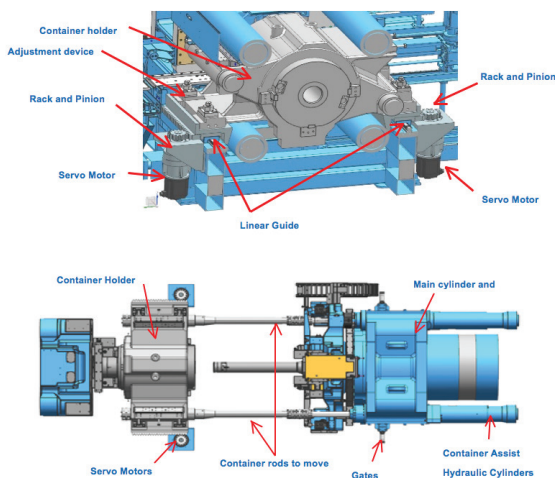

Figure 3. Container design with hybridized movement.

Energy Savings: The replacement of the hydraulic drives on both the container and discard shear with advanced servo-motors and mechanical drives not only reduces energy, but increases the acceleration and overall speed capability thus reducing the cycle time. The billet loader

was also converted and provides the same energy saving and speed benefits. A side benefit of conversion to servo-mechanical drives is a decrease in oil requirements and a reduced possibility of fire. Furthermore, the main ram is driven by a patent pending inverter controlled multi-pump motor system. The motors draw power only when in use and cease operation when not needed. Pump rotation and pump tilting degree of the axial piston motors are automatically controlled.

All together, the SS-Hybrid provides an energy savings of 46 kWh at 11.8 IPM (5 mm/sec) ram speed, a 35% reduction compared to the previous NPC-SSG3 series press. At a production level of 12,000 tons per year, this would result in a reduction in energy costs of US\$55,200 per year (assuming a unit cost of 15 cents/kWh).

Decreased Hydraulic Oil Volume: Based on feedback from customers and UBE field service personnel, the company chose to locate the oil tank, main pumps, auxiliary pumps, and manifolds on the floor behind the main cylinder (Figure 4). This location makes the tanks and pumps more accessible for easier press maintenance and filter changes. The side cylinders and the container assist cylinders can be changed on the side of the press, after removing the noise reduction covers installed on the main cylinder housing. The oil tank was designed to reduce oil volume by 25%, with a taller tank to eliminate oil supplied to the main ram through the prefilling valve. The drain pipe is designed so that it will not draw air into the system when there are variations in oil level.

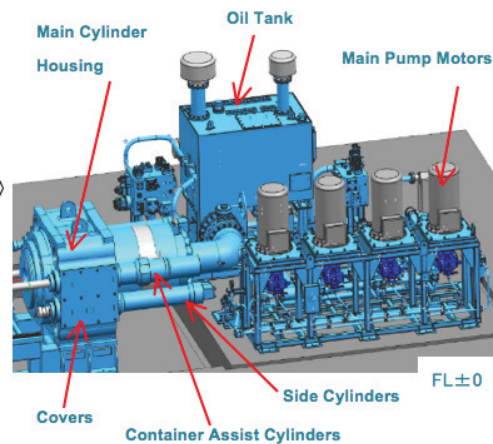

Figure 4. Position of the hydraulic tanks on the new press.

Fully Tested: UBE is also continuing the established practice of complete assembly, run-off, and final testing of its extrusion presses prior to shipment. Instead of shipping untested parts to the customer site and building the machine for the first time in the field, UBE firmly believes that only a complete and fully tested press will perform to the requirements it is designed for.

Conclusion

For more than a century, the UBE Group's operations worldwide have shared a frontier spirit, embracing continuous change in order to meet the demands of modern manufacturing for unique technologies. With the introduction of the new SS-Hybrid extrusion press, UBE continues to adapt to the evolving demands of aluminum extrusion manufacturing by taking on new challenges and introducing new technologies. The new extrusion press meets the needs of extruders by providing energy savings, improved operating efficiency, and a reduced environmental impact.